

# HALLER M3

5轴数控刀具磨床  
5-axis CNC Tool Grinding Machine

HALLER

苏州哈勒智能装备有限公司 Suzhou Haller Intelligent Equipment Co.,Ltd.

地址: 苏州市相城区富元路富阳工业坊10号厂房 215131

电话: +86 (0) 512 6983 3910

邮箱: info@szhaller.com

网址: www.szhaller.com

Add: No.10, FuYang Industrial Park, FuYuan Road, XiangCheng  
District, 215131, Suzhou, China

Tel: +86 (0) 512 6983 3910

Email: info@szhaller.com

Web: www.szhaller.com

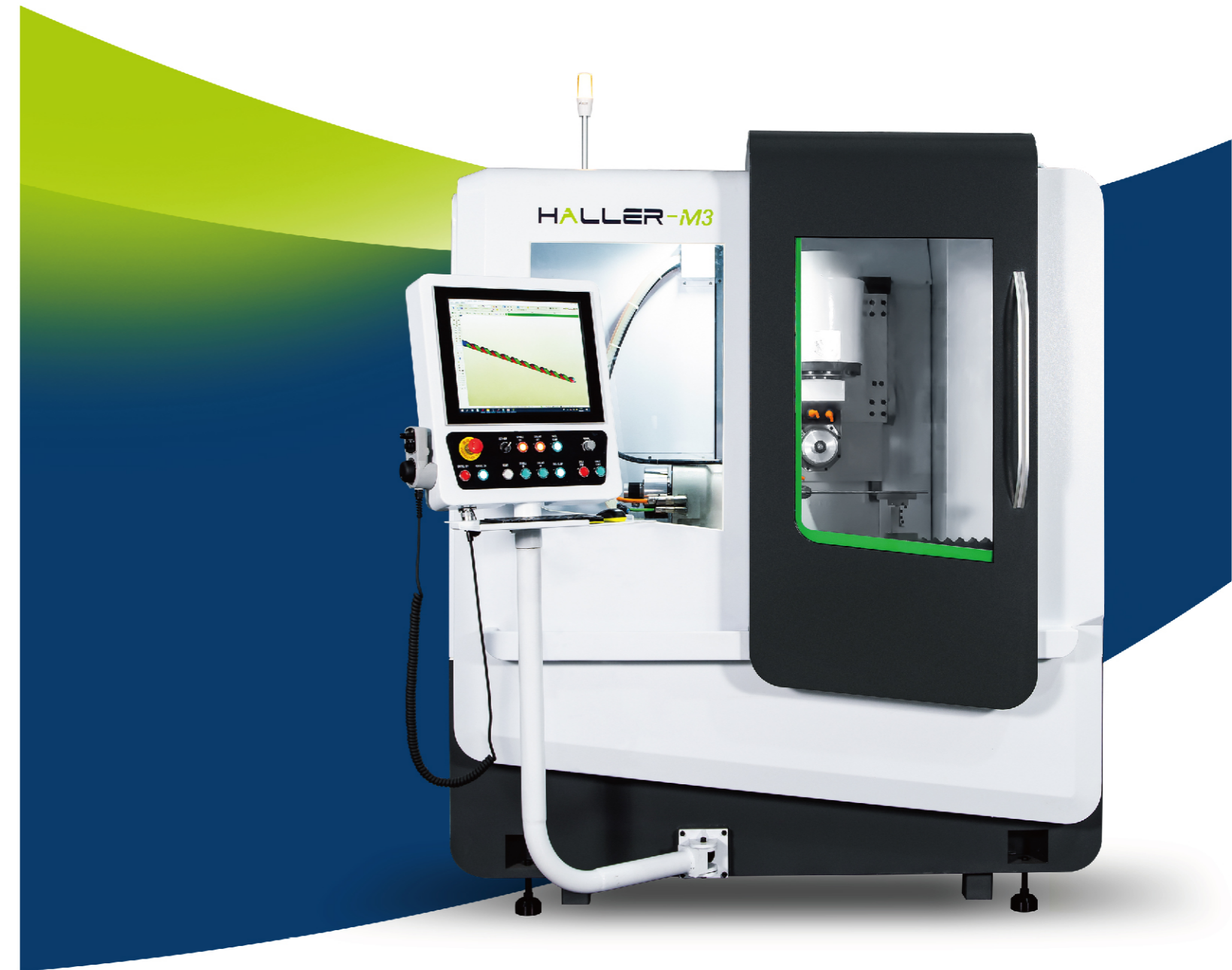



## HALLER-M3

哈勒智能是一家从事5轴数控智能设备设计、研发与生产的公司。2014年成立之初，哈勒智能引进德国高端5轴数控装备技术，在中国组装消化吸收，智能更迭，升级换代，以适应中国本土化方式为用户提供工具磨削整体解决方案。随着公司的不断发展与业务增长，研发设计与生产装配工艺日趋成熟，以及国家对依赖进口的高端卡脖子设备的扶持，哈勒智能开始涉足于工具磨削设备、医疗机械、传动机械、辅助配套设备以及相关应用软件领域的自主研发与制造。现有成熟5轴数控磨床PG系列和M系列以及医疗、传动等多个领域的系列产品，并已获得多项国内专利。哈勒智能不仅为客户提供多元化的解决方案，专业的应用培训，优质的售后服务，更能帮助客户解决产品加工难点，全方位满足客户定制化需求。

Haller Intelligent is a company engaged in the design, R&D and manufacturing of 5-axis CNC intelligent equipments. Since its establishment in 2014, Haller brought in high level 5-axis CNC machine technology from Germany, doing machine assembly in China, upgrading and optimizing to provide local customers with complete tool grinding solutions. As the company developing, business growing, R&D and assembly technology getting mature and government encouraging policy of high level import-dependent machines, Haller has started the innovative development, besides of the 5-axis tool grinders also further high level manufacturing machines, such as grinding machines for medical implants, grinding machine for globoidal cams, as well as gear chamfering machines. The core technological advantages concentrate in setting-up the mathematical models, developing the application software etc. Because of those innovative activities Haller has been getting numerous approved patents and many innovation awards as well. Haller not only provides customers with diverse solutions, professional application training, excellent after-sales service, but also can help customers solve production difficulties to satisfy all-round customized demands.

## 内部概览 Inside Overview

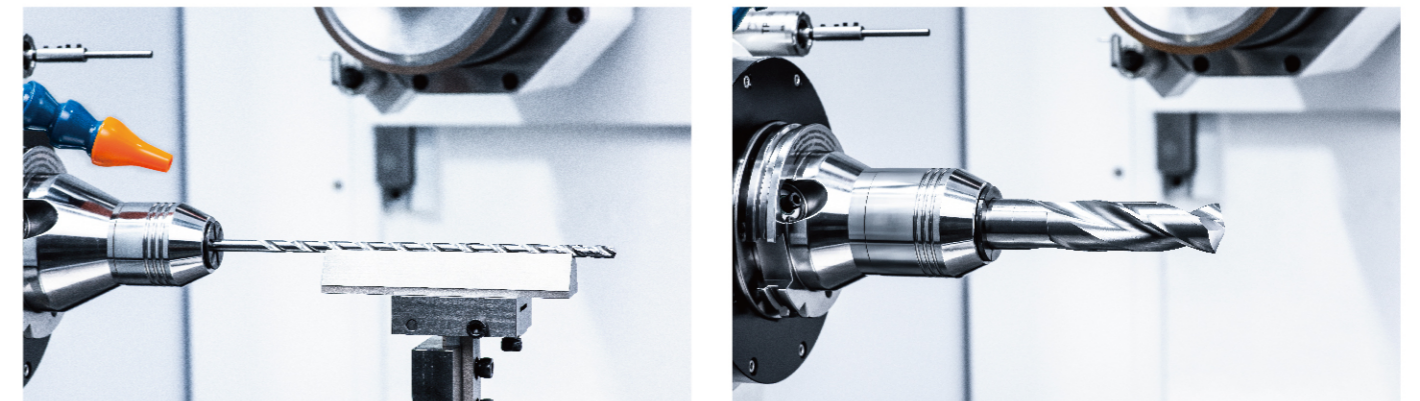
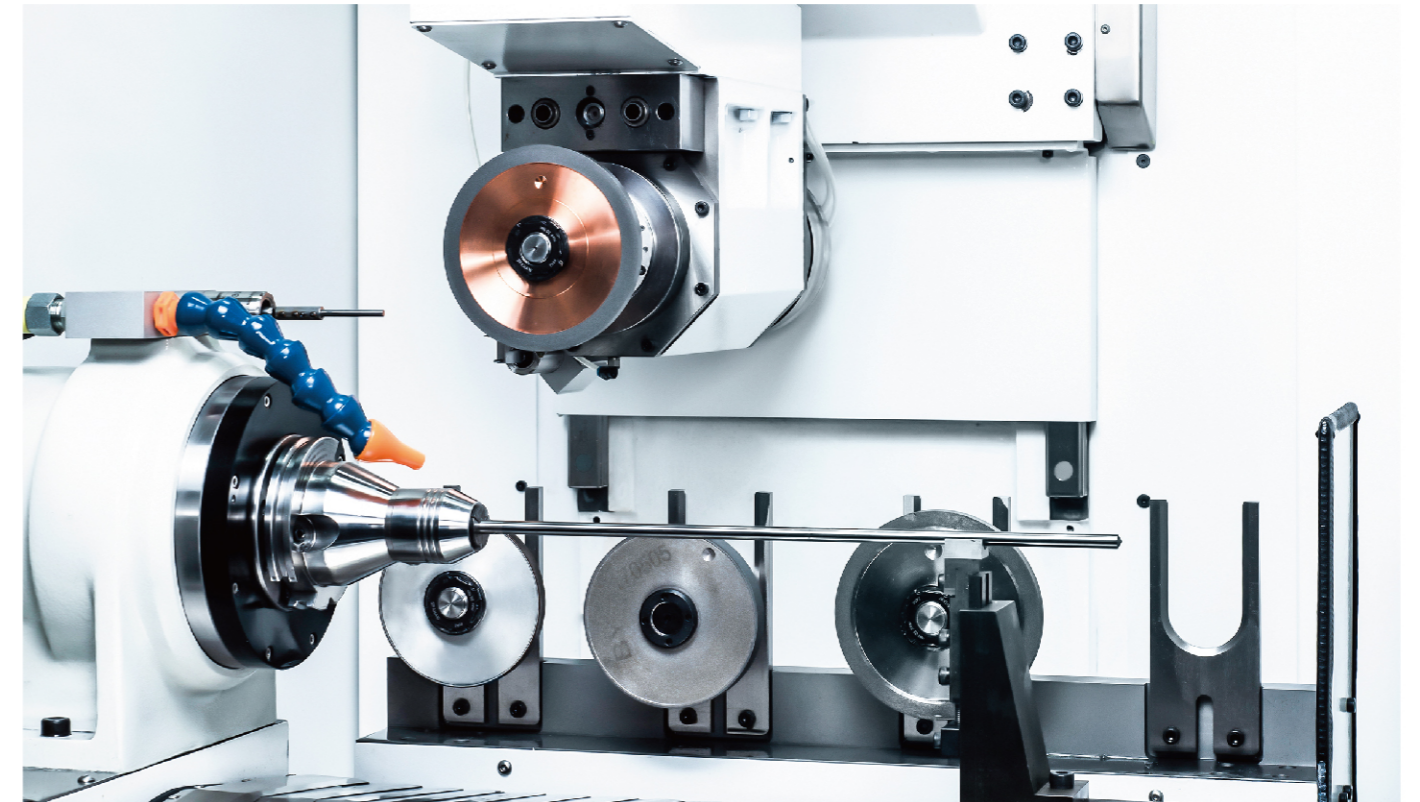

## 功能优势 Function Advantages

- 机床外形大气美观。
- X、Y、Z轴高精度直线电机，超高推力密度；配有全闭环高精度海德汉直线光栅尺，稳定性持久。
- 高扭矩磨削电主轴，加工快捷，稳定性高，低损耗。
- 工件、砂轮全方位自动在线测量系统高效准确，保证了加工刀具的稳定性。
- 采用全球领先的NUM控制系统与NUMROTO磨削软件，简单易学。
- 个性化操控面板，直观简便。
- 配合托架顶尖，可实现超长磨削。
- The machine looks beautiful.
- X, Y, Z axis high precision linear motors have super-high thrust density, equipped with full closed-loop high precision linear scale, durably stable.
- High torque motor spindle, fast processing, high stability, low power loss.
- Automatic full-directionally internal measuring system for both work piece and grinding wheel, efficient and accurate, which ensure the tool machining stability.
- The worldwide leading NUM control system and NUMROTO grinding software are easy to learn.
- Individualized control panel is visually simple.
- Equipped with tailstock, to realize super grinding of long tool.

直线光栅尺  
Linear scale

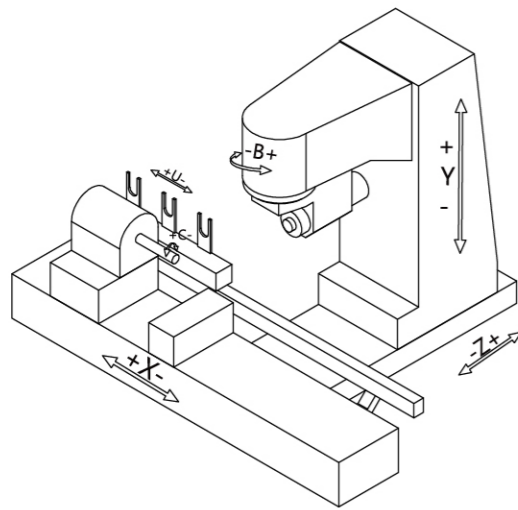

### ► 高精度直线电机 High-precision Linear Motor

X、Y、Z轴直线电机，具有超高推力密度，低顿力，配有海德汉全闭环高精度直线光栅尺，直线光栅尺具有测量方向上的高刚性、热特性好等特点，全闭环控制模式能消除潜在的多个误差源，从而保证了机床高精度定位和高速加工时的稳定性，且长期持久。

The X, Y, Z axis linear motors with super-high thrust density; equipped with HEIDENHAIN closed-loop high precision linear scale. The linear scale has the characteristics of high rigidity in measurement direction and good thermal property. The full-closed-loop control mode can eliminate potential multiple error sources, thus ensuring the stability of high precision positioning and high speed machining during tool machining in long term stability.

### ► 自动在线测量系统 Automatic Internal Measuring System

#### 工件测量系统 Workpiece measuring system

在线对工件进行迅速定位，在刀具加工过程中测量并修整工件参数，保证了刀具加工的质量。

The work piece is internally rapid-positioned, and the work piece parameters are measured and adjusted in the process of tool machining to ensure the tool quality.

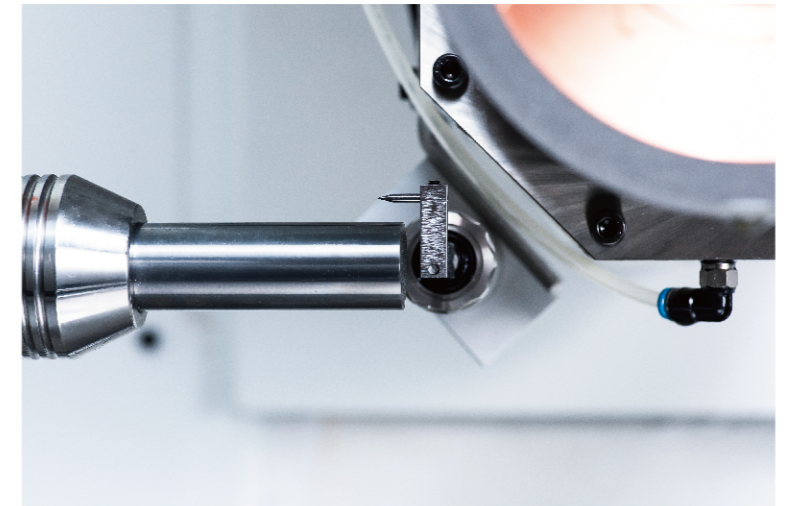

#### 砂轮测量系统 Grinding wheel measuring system

机床在线测量砂轮参数，迅速便捷，有助于减少机外测量检测时间，避免人工检测错误，准确高效，从而保证刀具加工稳定性，提高加工效率。

Machine automatic internal measurement of grinding wheel parameters, fast and convenient, to helpfully reduce the measuring time outside the machine, avoid manual checking errors, accurately and efficiently, so as to ensure the stability of the tool machining and efficiency is improved as well.

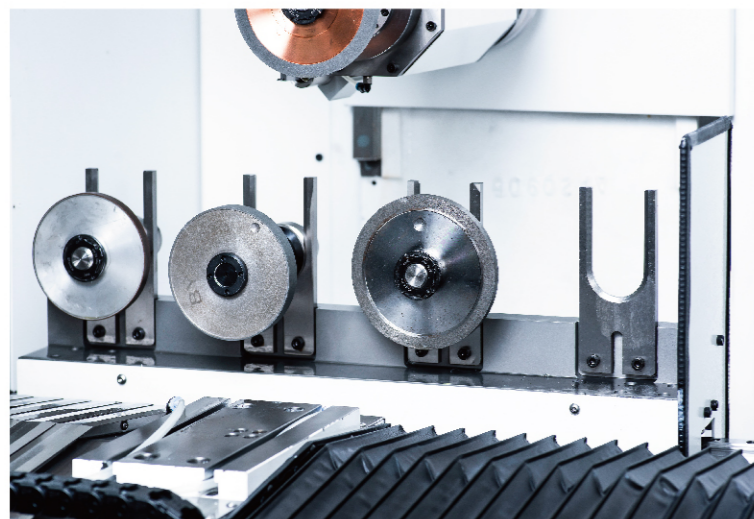
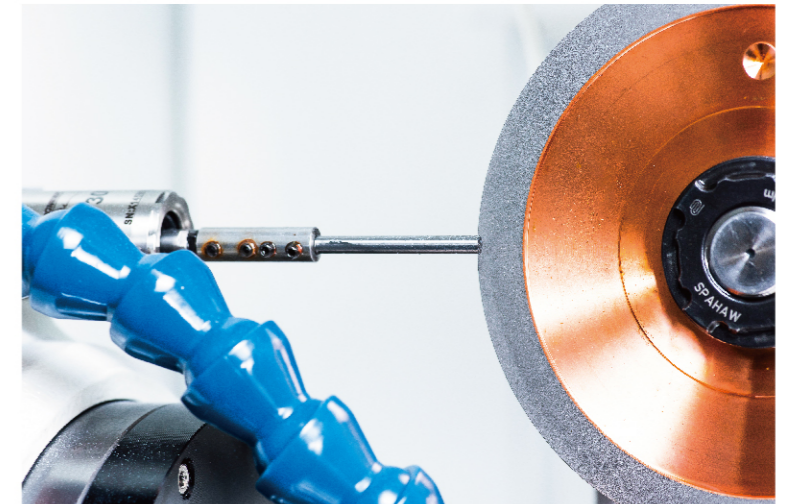

### ► 4工位砂轮库 4-package wheel changer

4工位砂轮库，机内自动更换砂轮，最大砂轮直径150mm。

4-package wheel changer, automatically change the grinding wheel inside machine, wheel max diameter 150mm.

### ► SK50工件轴 Workpiece Axis

SK50工件轴（C轴）采用高扭矩直驱电机，分辨率可达0.0001°，最高转速1000rpm。六轴电机自带独立油冷系统，配备自动伺服电缸砂轮库。

SK50 work piece axis (C axis) uses torque motor with resolution of 0.0001°, maximum speed of 1000rpm. Separate oil cooling system for 6 axes motors, equipped with automatic servo cylinder wheel changer.

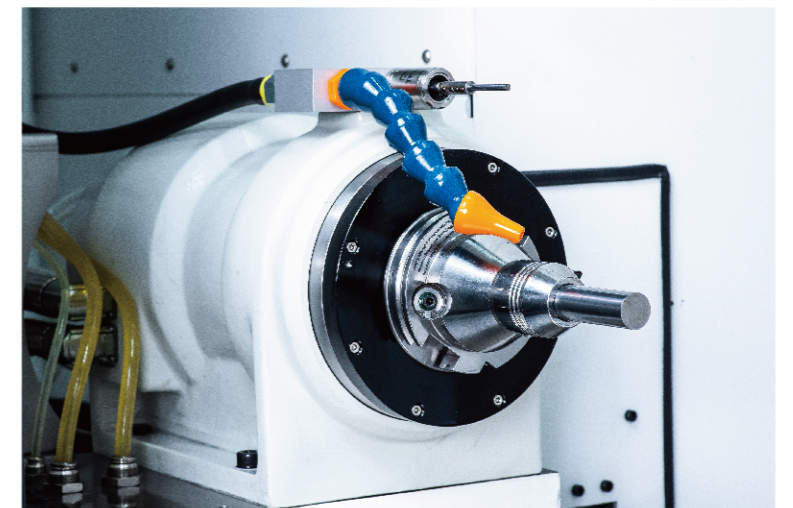

## 稳定可靠的控制系统

Reliably Stable Control System

### NUM-Flexium<sup>+68</sup>

- 新一代NUM-Flexium<sup>+68</sup>数控轴系统；
- 高分辨率直驱电机；
- 19寸TFT彩色显示屏, 个性化操控面板, 直观简便；
- 优化设计的电器柜易于修理；
- 通过光纤链接的可旋转操作面板方便操作；
- 直接安装在机床电器柜里的电脑为今后的维护、更换、升级提供了便利从而节省了费用。

- Digital CNC control unit for highest requirement;
- High resolution direct drive motor;
- 19-inch TFT colour display with uniquely simple operating panel;
- Electrical cabinet with optimal arrangement and accessibility for easy servicing;
- Rotatable panel connected via Ether-cut simple for simple operation;
- An office PC can easily be integrated in the electrical cabinet to promote maintenance, rapid replacement and updates without high investment costs.



## 简单的磨削软件

Easy Grinding Software

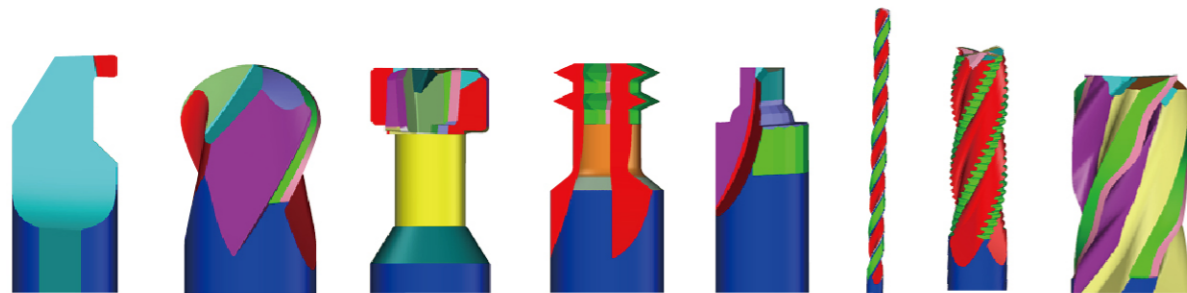

NUMROTOplus<sup>®</sup>是全球领先的用户软件, 多年来成为高精度刀具磨削中的成功引领者。NUMROTOplus<sup>®</sup>软件简单易学, 普通工人即可在短时间内迅速学会并熟练操作, 大大降低工人培训难度, 为客户降低培训成本。

NUMROTOplus<sup>®</sup> is the worldwide leading user software, successful trendsetter in high-precision tool grinding for many years. NUMROTOplus<sup>®</sup> software is simple and easy to learn, ordinary workers can quickly acquire grinding skills and operate proficiently in a short time, greatly reducing the difficulty of training workers, and reducing training costs for customers.

## 技术参数

Technical Data

磨削范围 Grinding range	
刀具加工直径范围 Diameter range for tool production	1-32mm
最大刀具修整直径 Max. diameter for tool regrinding	200mm
最大加工长度 Max. processing length	340 (380) mm
控制系统 Control System	
CNC 控制部分 CNC control unit	NUM-Flexium <sup>+68</sup>
TFT液晶显示器 TFT liquid crystal display	19寸 Inch
磨削软件 Grinding software	
NUMROTOplus <sup>®</sup> 铣刀, 钻头, 非标刀具, 3D模拟软件 NUMROTOplus <sup>®</sup> milling cutters, drills, special tools, 3D simulation software	
测量系统 Measurement system	
刀具测量 Tool measurement	3-D 探针 Probe
砂轮测量 Grinding wheel measurement	3-D 探针 Probe
磨轴主轴 Grinding spindle	0-8000rpm
主轴最大功率 Max. spindle power	24KW
砂轮 Grinding wheels	
砂轮最大直径 Max. wheel diameter	150mm
4工位砂轮库 4 package wheel changer	NC控制 NC Controlled
每个砂轮连杆可装 Grinding wheels per adaptor	1-3片砂轮 1-3 pcs grinding wheels
冷却阀 (程序控制) Cooling via cooling valve (Program-controlled)	3组 3 Valves
砂轮杆接口 Grinding wheel interface	HSK50C
C轴(工件轴) C-axis (Workpiece axis)	
C轴 C-axis	SK50
工件夹紧系统 Tool clamping system	气动 Pneumatic
驱动形式 (直驱) Drive (Direct drive)	力矩电机最大1000rpm Torque motor max.
冷却方式 Cooling	
X/Y/Z/B/C/主轴 X/Y/Z/B/C/Spindle	独立油冷 Separate oil cooling
油雾接口 Oil mist interface	Φ150mm

轴行程 Axis travel	
X轴 X axis	450mm
Z轴 Z axis	340mm
Y轴 Y axis	205mm
速度 (X轴) Speed X axis	20m/min
速度 (Z轴) Speed Z axis	10m/min
速度 (Y轴) Speed Y axis	10m/min
分辨率 (C轴) Resolution C axis	0.0001°
旋转轴 (B轴) Rotation axis B axis	225°
分辨率 (B轴) Resolution B axis	0.0001°
X Y Z 轴 X Y Z axis	直线电机 Linear Motors
机床尺寸 Machine dimensions	
长度/宽度/高度 Length/Width/Height	1900mm*2463mm*2230mm
重量 Weight	Appr.8000kg
电源 Power supply	3×400V-50HZ/63A
功率输入 Power input	32KW
压缩空气 Air Supply	≧ 6bar
颜色 Colour	RAL7035/RAL9003

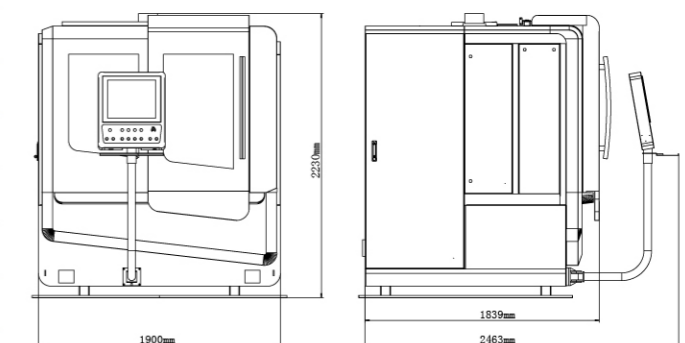

\* 哈勒智能保留对技术规格参数修改或升级的权利  
Suzhou Haller reserves the right to modify or upgrade the technical specifications